

Measuring Food Packaging Materials

Low-coherence interferometry measures the inside layer of packaging on a continuous production line.

by John Hart, Lumetrics

Packaging is an important aspect of the food industry, especially for frozen items. Packaging that is too thin or that is not made of the right materials could lead to “freezer burn”; on the other hand, overprotecting food leads to unnecessary costs.

In the past, the standard practice was to overengineer material layers so that they always maintained protective barrier properties. This might mean applying 20 percent or more excess material to the final product. At more than \$5 per pound, this material could cost more than several hundred thousand dollars a year.

One reason for the waste of packaging material is that testing it during manufacturing was a challenge. One method is to take measurements of the material in a continuous production line, where the film is made immediately before the meat products are packaged. This is done every 30 minutes by manually cutting a section of the material as it is produced and taking it to a laboratory, where it is dissected to determine the layer thicknesses. In that scenario, a manufacturing error would have indicated that a large amount of product might have been packaged inadequately. The meat would have required manual inspection or disposal at significant cost.

Dual-wavelength interferometry, a technology developed by Eastman Kodak of Rochester, N.Y., can help test packaging for meat products. The technology was used by the film industry to help characterize acetate-based products, and, as the digital market grew, the same technology was applied to sensor measurements.

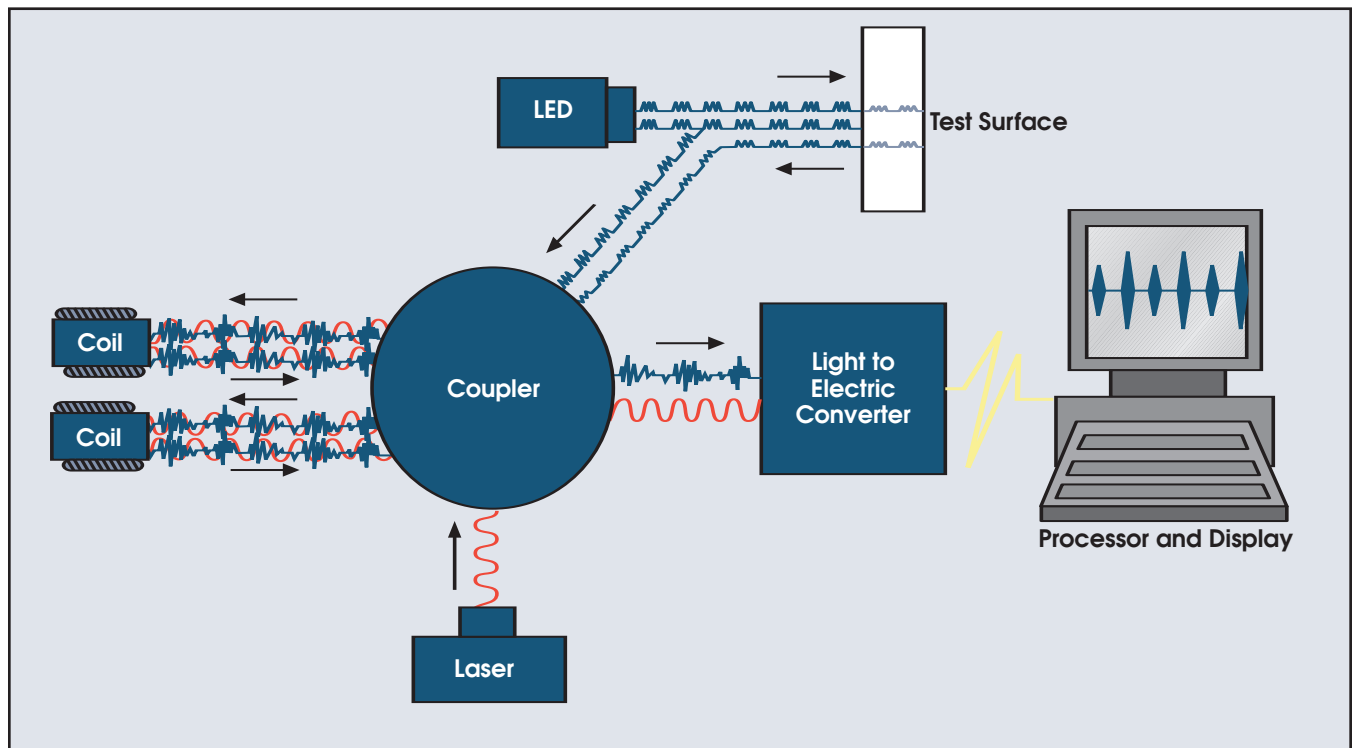

Figure 1. The OptiGauge measurement system works using index of reflection differences from the multiple layers in the film. Light is projected from an LED onto a surface. Some light is reflected back and sent to the coupler, where it is merged with laser light. As the light is transmitted through the coils, the fiber stretchers cause a path length change. When this is coupled with the resultant generation of interference patterns, the measurement peaks are created. The laser acts as an internal clock and reference to measure the optical distance between the peaks. The converter and the processor contain the specialized algorithms and application software that convert the optical measurements into those displayed on the screen.

Lumetrics Inc., also in Rochester, licensed this technology platform with the intention of adding application-specific fixturing to take measurements of extruded film.

A major food processor is using the resulting system, the OptiGauge, to measure the inside layer of a three-layer packaging material in a continuous food-packaging line (Figure 1). The specialized clear polymer is co-extruded between two other layers of material in a continuous web. The polymer was developed specifically for this application.

The system employs low-coherence dual-wavelength interferometry, which uses the low temporal coherence of a broadband light source — a superluminescent LED (as opposed to a highly coherent laser source) — to produce interference fringes only when the arms of the interferometer are path length-matched with the coherence length of the light source. No coherence fringes are detected beyond this range. This technique does not suffer from the 2π ambiguity of high-coherence interferometry and, therefore, can axially resolve a multilayer structure such as a three-layer plastic. To ensure high accuracy, the dual-wavelength technology uses a high-coherence interferometer at a second wavelength to monitor the displacement of the low-coherence interferometer. It acts as a time clock for the system.

To implement this system in the food processors' production facility, Lumetrics worked with a Rochester-based systems integrator, Optimization Technologies, to design, install and qualify a closed-loop measurement system that now monitors eight separate webs of packaging film over four packaging lines and optimizes each layer thickness so that the barrier properties meet the material design specifications (Figure 2).

The interferometry measurements are combined with scanning stages and multiple probes to scan the various webs. Each optical probe is moved over the material with mechanical slides. Via microelectromechanical systems (MEMS)-based 1×8 switches, data is collected consecutively over each web and fed back through a control computer to each extrusion machine, which adjusts the layer thicknesses to meet the desired specification. The control software is designed to produce operator alerts in the event that the material parameters are outside the control limits; it also keeps a complete log of each processing line. If desired by the customer, one channel of the optical switch can be used to constantly measure a NIST-traceable calibration standard, assuring reliability of in-process data collection.

Light-based systems bring the advantages of speed, safety, long life, accuracy and noncontact to food industry applications, supporting the industry's ongoing efforts to improve product appearance, to increase shelf life and to maintain package integrity. □

Meet the author

John Hart is president of Lumetrics in Rochester, N.Y.; e-mail: jhart@lumetrics.com.

Running head: Photonics and Food

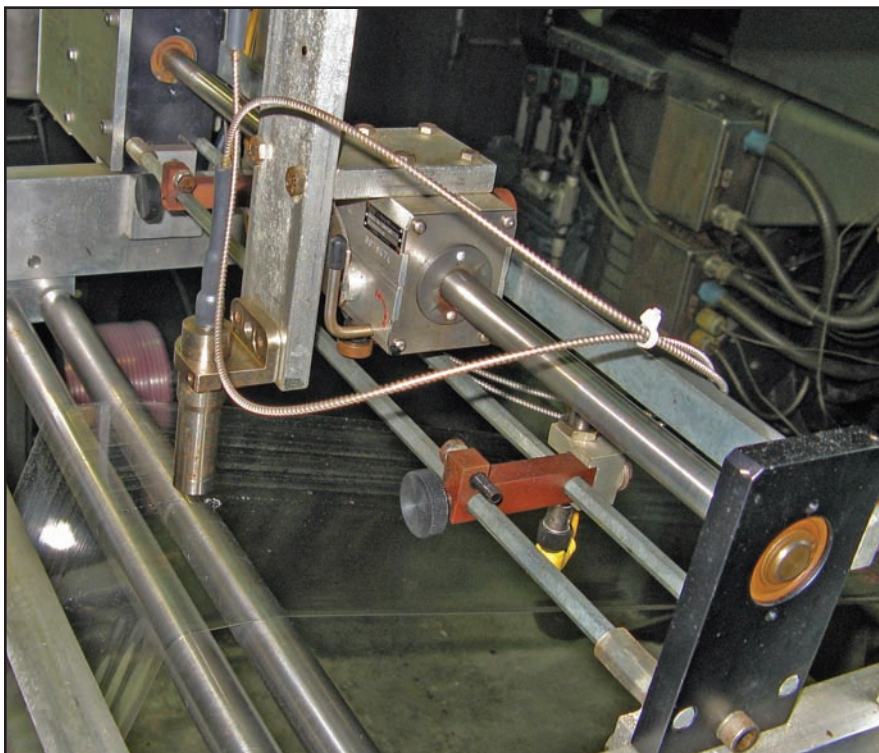

Figure 2. The closed-loop measurement system is installed right on the production line. It monitors eight webs of packaging film over four packaging lines and optimizes each layer thickness so that the barrier properties meet the material design. This picture shows one of the scanning systems and its probes directed at the web of film.