



*Advanced Catheter
Measurement System*

*John Hart, President ,Lumetrics
Booth #1948*

Return on Investment ROI

Advanced catheter measurement using the LumetriScan 360 will:

- **Increase Revenue:**
 - Enables new product development
 - Increase speed to market
- **Reduce costs**
 - Eliminate scrap, speed inspection, reduce returns
- **Insure FDA compliance**
 - Ensure data integrity, accuracy, reliability
- **Lower labor costs**
 - Reduce manual intervention, automate processes

Who Is Lumetrics?

- **Leader in measurement solutions to the medical market since 2003**
 - Multiple applications in 6 of the top 11 medical device companies
- **Give customers outstanding ROI**
 - Multiple sales into numerous Fortune 500 customers
 - Medical, ophthalmic, pharmaceutical, food packaging, glass, more
 - New applications and recertifying for better FDA compliance
 - Conduct 360 evaluation as part of application assessment
- **System Solutions Capabilities:**
 - Optical Design
 - Custom Software Development – Process Control, Coating & Laminating
 - Mechanical Systems Design – Scanners, Inspection Fixtures, Robotics
 - Partnering with System Integrators for Manufacturing Process Control



OptiGauge System



- OptiGauge
- Controller w/ display, keyboard, mouse
- Measurement probe

OptiGauge Features & Benefits

- **Non-contact, non-destructive, non toxic**
- **Flexible: real-time online or lab use**
- **Measures multiple layers simultaneously independent of substrate measurement or variability**
- **Immediate results**
- **Portable and easy setup allows use as a diagnostic tool**
- **Multiple probes in flexible configurations, top and bottom views, easy to add and move probes**
- **Multiple applications with single system**
- **Continuous enhancements increasing applications usage**
- **Rapid startup “make ready” time decreased**

OptiGauge

How does this magic work?

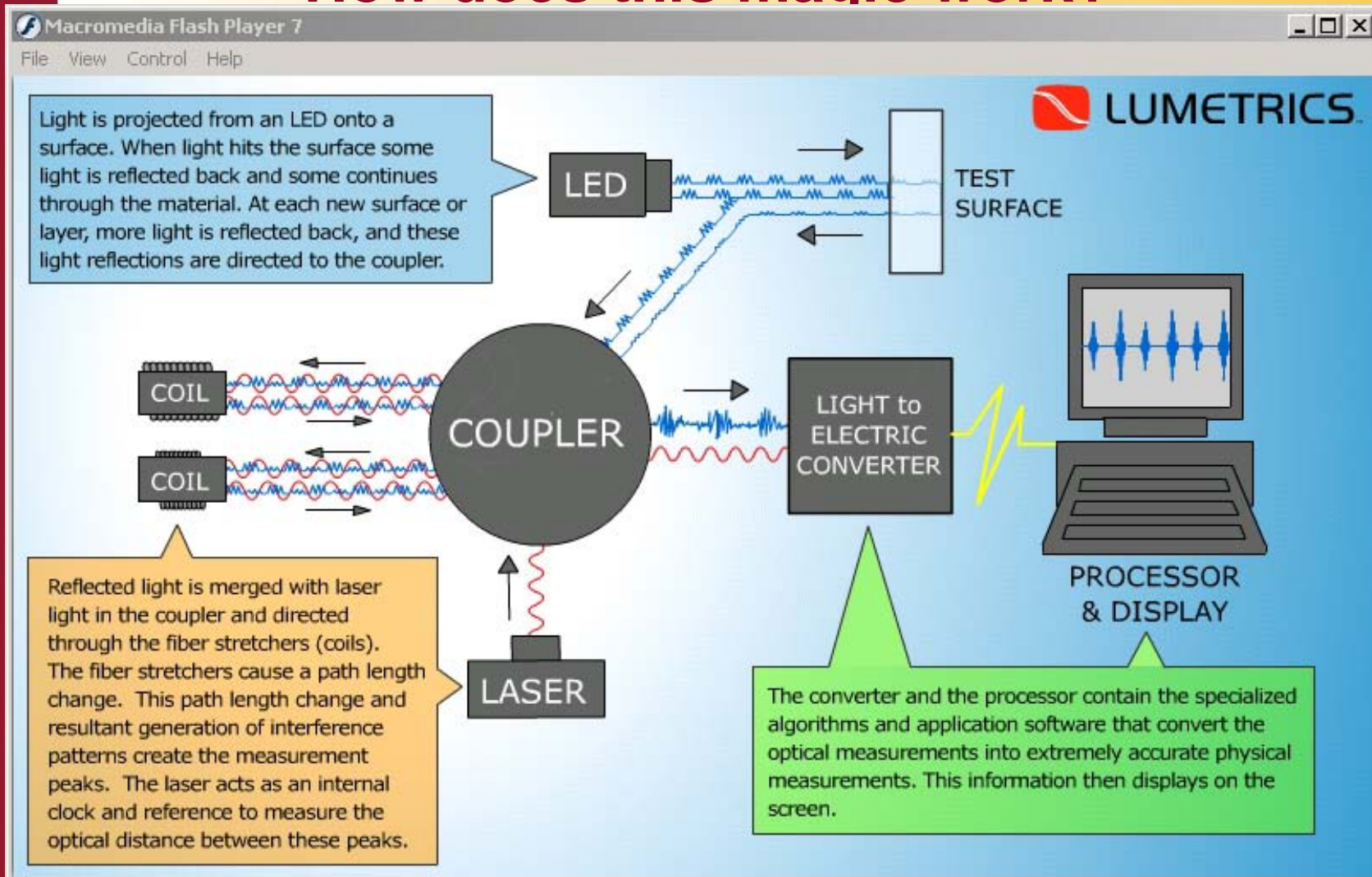

Inspection Methods Tubing and Balloons- Old



- Subjective readings
- Inherently variable
- Destructive
- Manual data collection
- Heavy operator involvement

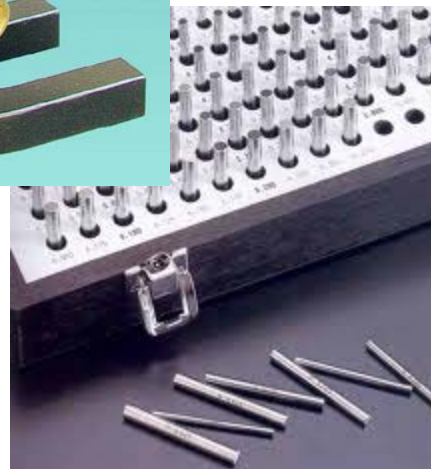

Inspection Methods - New



- Objective readings
- Accurate and consistent
- Non-contact, non-destructive
- Data integrity and automatic data transfer
- Limited operator involvement

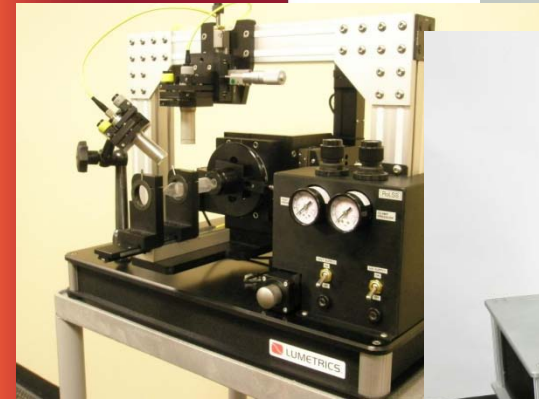

Inspection Methods - Advanced

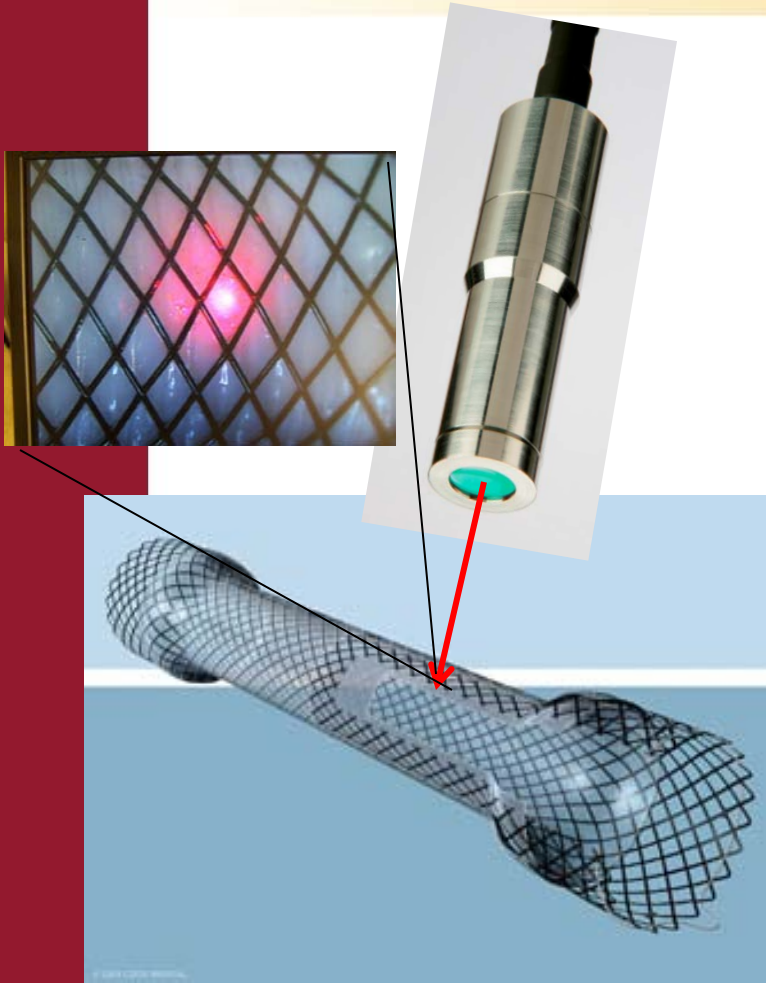

- **Integrated camera system**
 - Defects, impurities, dimensions
- **Partner integration**
 - Burst testing, leaks
- **Full factory automation**

Why Change Inspection Methods?

- Generate new revenue
 - Customer A said "...without your OptiGauge I would not have been able to understand the process variables and manufacture my balloon".
- Improve time to market
 - TesCo reduced start-up time on new production line from 4-6 months to 4 weeks
- Reduce cost and improve quality
 - Lumetrics worked with subcontractor of top 5 medical device mfg on film consistency. End user "... film specs so good I can tighten up product spec and produce a safer and more accurate final product".
- FDA compliance
 - Critical data integrity, accuracy, repeatability, and traceability

Introducing - LumetriScan 360 - 36

- Automated inspection – load and go
- Full data collection and storage
- Measurement flexibility
- Customizable reporting
- Tubing and balloons
- Rapid throughput



Balloon Measurements

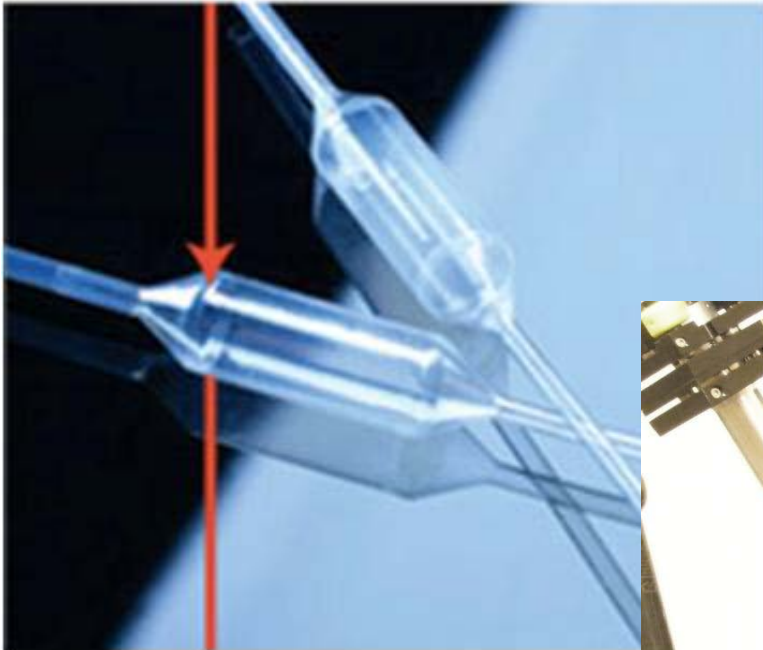

Measure any location
on any shape balloon
under constant or
variable air pressure

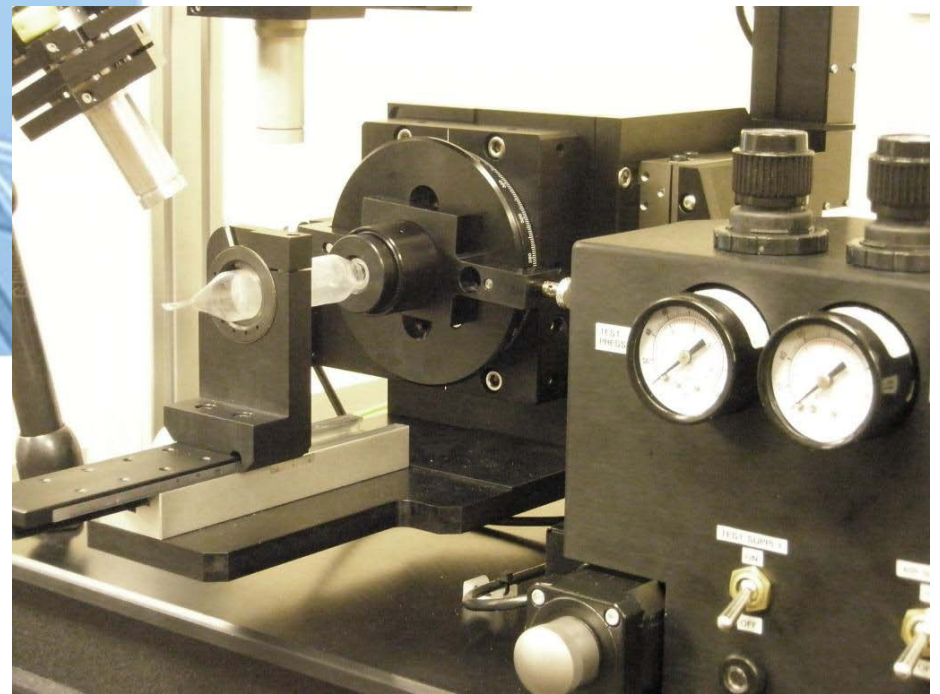

Generic Balloon Display

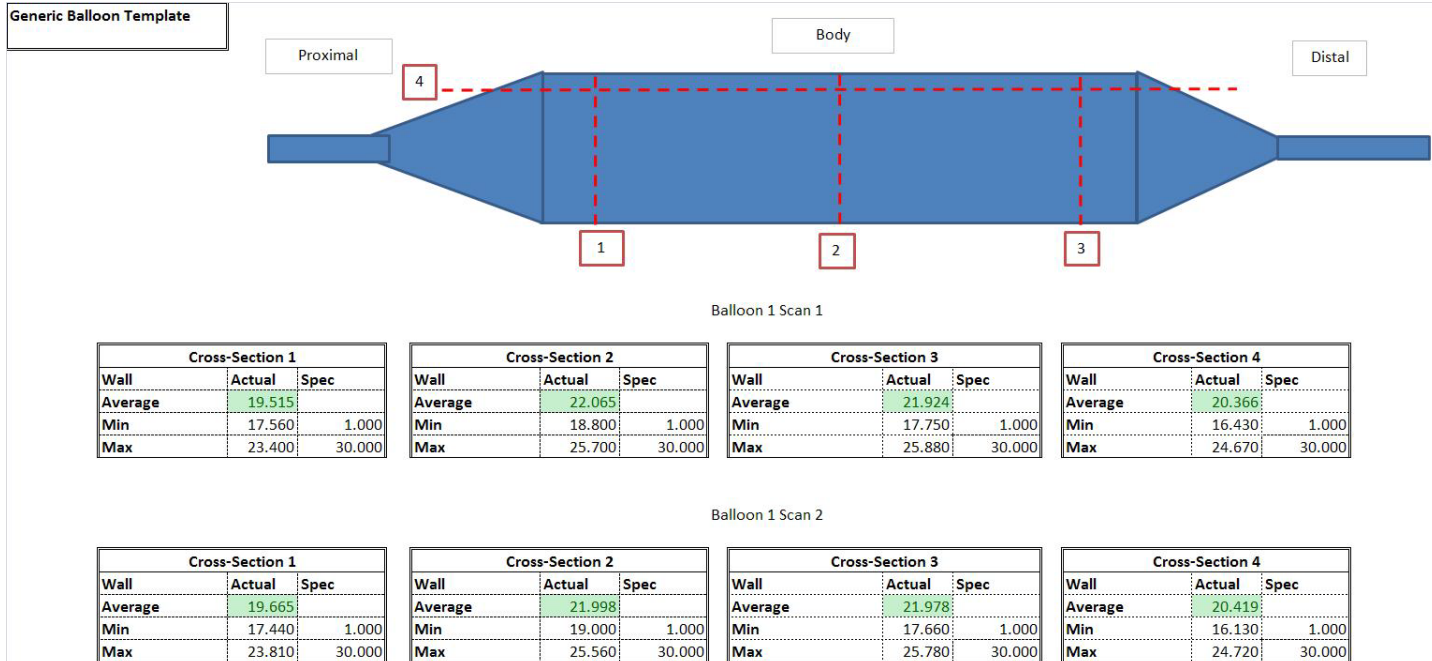

- Unlimited recipe creation and measurement
- Automatic pass fail criteria display
- Multiple displays modifiable in Excel

Automated Tubing Measurement

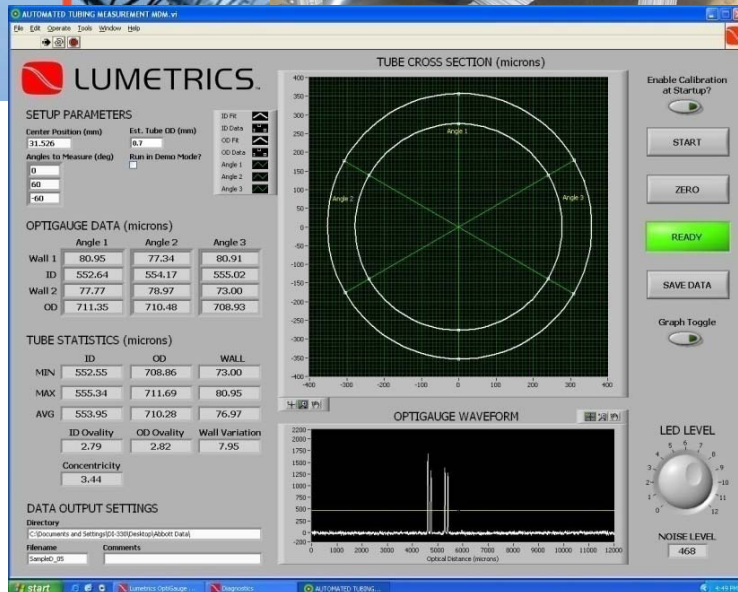
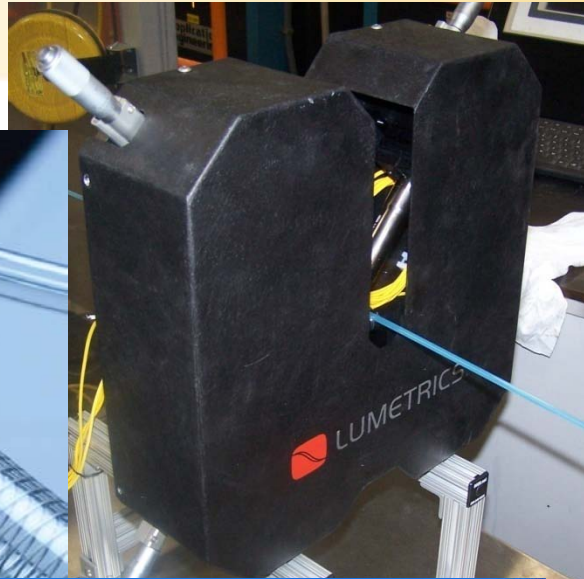
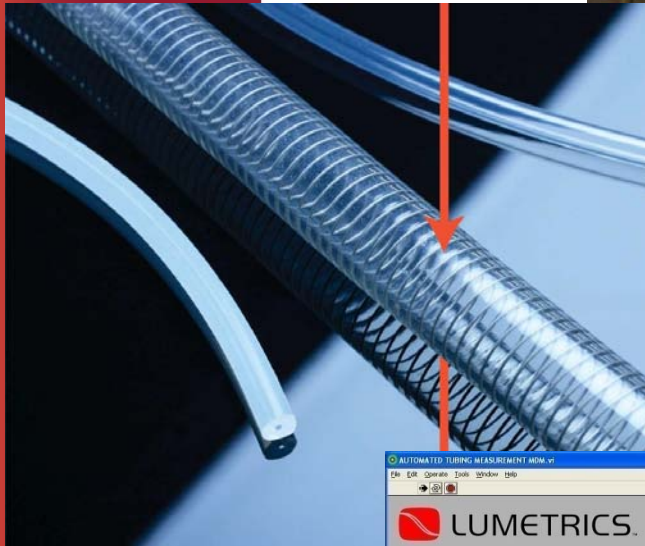

New Inspection Methods Mean Better ROI

- **Increase Revenue:**
 - Understand your processes to enable production
 - Spend less time guessing – provides concrete data
- **Reduce costs**
 - Monitoring at-line and online improves product quality
- **Insure FDA compliance**
 - Don't settle for status quo – the FDA won't
- **Lower labor costs**
 - Use repeatable, reliable, cost effective alternatives

Thank You

Call us any time

Rochester: 866-524-2455

John Hart: 585-214-2455 x 101

Steve Heveron-Smith: 585-214-2455 x 102

Steve Kelly: 585-214-2455 x 121

Sales@lumetrics.com

